

Operating Instructions
Tapping Holder GHN with Morse Taper

1. Product features

- for cutting of internal threads with drill presses, radial drill presses and vertical drill presses with reversing spindles
- for the efficient machining of threads in through and blind hole threads
- without rapid backout
- safety clutch infinitely adjustable by rotation and locking of graduated collar
- conversion from slipping clutch to friction operation by simply turning over the cam ring (for small threads)
- suitable for right or left hand threads
- clamping jaw mechanism grips all tap shanks within unit's capacity including intermediate and inch sizes
- easy to operate without any special previous knowledge

2. Executions

GHN Tapping Holders are supplied with Morse Taper with tang DIN228-B:

<u>Model</u>	<u>Cutting range *</u>	<u>Max. speed</u>
GHN10 with MT1 or MT2	M3-M10 (M12) #6-3/8" (1/2")	600
GHN16 with MT2 or MT3	M6-M16 1/4"-5/8"	400
GHN27 with MT3 or MT4	M14-M27 (M30) 9/16"-1.1/8" (1.1/4")	250

* Cutting range refers to materials with tensile strength of 500 N/mm²

() for light machining only, e.g. aluminium, grey cast iron, steel up to max. 350 N/mm² and fine pitch threads

3. System structure

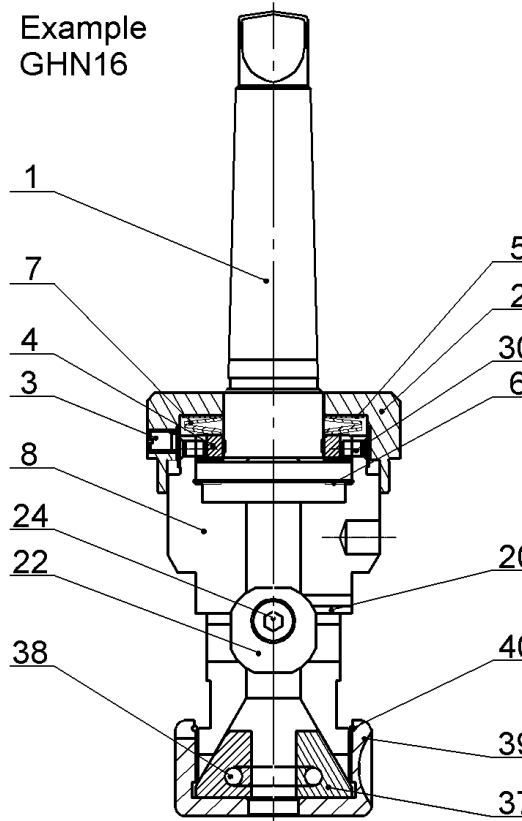

<u>Part #</u>	<u>Description</u>
1	Taper Shank MT2 or MT3
2	Cap Nut
3	Screw for 2
4	Cam Disc
5	Plain Washer
6	Washer
7	Cup Spring
8	Body
20	Dowel Pin
22	Left & Right Nuts (Set)
24	Stud LH/RH thread
30	Pin for 4
37	Jaws (Set)
38	Spring for 37
39	Clamping Nut
40	Lock Ring for 39

4. Tap mounting

Push the tap into the opened jaws and locate into square drive. First clamp the square drive and then the tap shank by turning the clamping (chuck) nut in a clockwise direction.

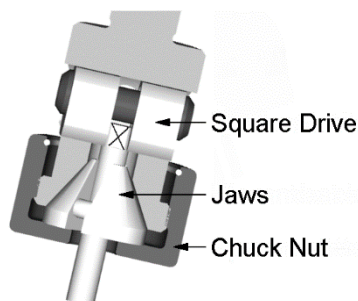

5. Determining the torque setting for tapping

The torque setting of the safety clutch is carried out by means of the cap nut. The line scale is there to provide information about the torque settings employed, as different materials also require different torque settings for tapping.

Important: Use a new tap for this adjustment!

Procedure: Loosen the screw for cap nut and undo the cap nut a little, so the cup washers are only slightly pre-tensioned. Start the machine and start tapping. If too little torque has been set, the safety clutch will jump and clatter. Stop the machine and tighten the cap nut a little (setting the clutch more tautly), then restart and continue trying to tap. Repeat this action until the thread is cut properly, and without the safety clutch jumping. The screw for cap nut can then be retightened.

When the torque is set correctly there is no risk of breakage of the tap if it comes to a stop because it is jammed with swarf, or on reaching the end of a blind hole.

6. Tapping

Important: The cap nut must be adjusted after point 6!

The tap is to be applied centrally with moderately brief pressure on the drill feed lever, and then to be followed through without any feed pressure. High feed pressure will result in pitch errors in the cut thread. Use appropriate lubricants

On reaching the desired thread depth, reverse the work spindle, pull up the centre sleeve via the drill feed lever and, pulling gently, guide the tap out of the thread.

If you do not pull the centre sleeve the tap will stop turning. If you pull too violently on the centre sleeve this may result in pitch errors, and in extreme cases to damage to the screw tap holder.

The depth of cut in the case of blind holes can be restricted by means of the drill stop usually available. Approximate thread depth setting - 2 mm.

7. General instructions

a) Machining high-tensile materials

- tighten the cap nut further, or
- in the case of GHN27 (threads over M16): cup springs must be fitted pointing in one direction. This means that the claw coupling is more tautly pre-tensioned and acts with less elasticity.

Procedure: Loosen the screw for cap nut, unscrew the cap nut, remove the plain washer and cup springs, and replace them pointing in one direction.

Then screw the cap nut on again and carry out torque-setting according to point 6.

b) Light alloys, plastics and small threads (up to M5)

In this case you are recommended to exchange the safety clutch for a friction drive. This is achieved by turning round the inserted cam and laying it with its flat surface against the toothed surface of the shank.

This instruction should also be followed if the machining of threads in blind holes, such as in cast components, causes difficulties when the toothed coupling engages.

Procedure: Loosen the screw for cap nut, unscrew the cap nut, remove the plain washer and cup springs, and cam disc. Put the plate with its flat side onto the shank cam, then fit the cup springs, the plain washer and the cap nut. Torque adjustment is now carried out in accordance with point 6.

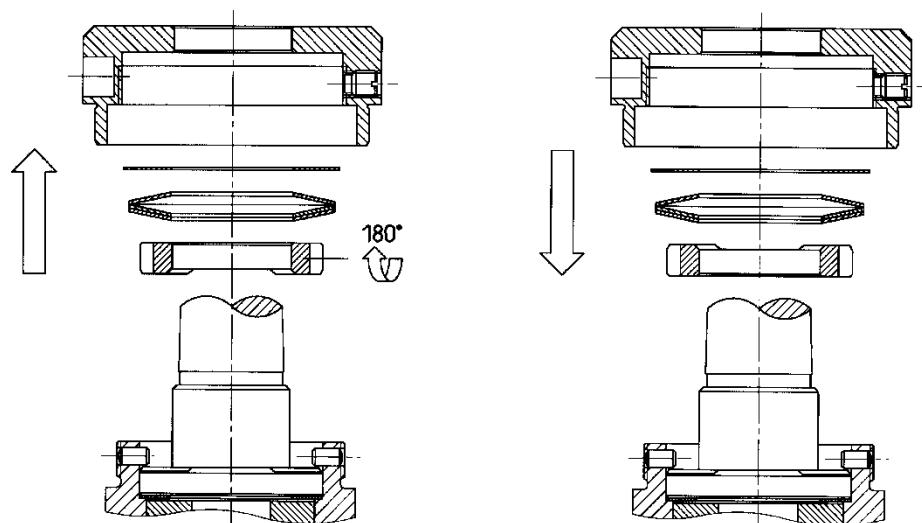

Example GHN16

8. Factory-installed direction for the cup springs

Shank side ↑

GHN10

GHN16

GHN27
(to M16)

GHN27
(over M16)

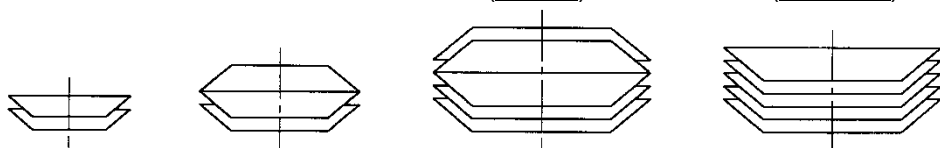

Tap side ↓

9. Maintenance

In continuous operation we recommend that the cam disc and the cam on the shank should be sprayed with Molykote G-rapid plus (graphite spray) at approximately 3-monthly intervals.

Procedure: Loosen the screw for cap nut, unscrew the cap nut, remove the plain washer and cup springs, and cam disc. Spray cam disc and shank cam, then insert

cam disc with cup springs and plain washer. Screw the cap nut on again and carry out torque-setting according to point 6.

10. Repair

The GHN tapping holder is very sturdily constructed and has a long service life. Faults may occur, however, as a result of wear, leading to breakdowns. The parts subject to wear can be replaced as described in point 7b.

The repair kits listed below are matched and must always be replaced as a unit.

Repair kit	Description
1 (Slipping clutch)	- shank with cam (please quote MT size) - cam disc - spring washer package
4 (Clamping part)	- 1 left & right nuts (set) - 1 stud LH/RH thread

Order numbers

Repair kit	GHN10 Order-No.	GHN16 Order-No.	GHN27 Order-No.
1	MT1 56010890010	MT2 56020890010	MT3 56030890010
	MT2 56011890010	MT3 56021890010	MT4 56031890010
4	56311890040	56322890040	56333890040

Sales by:

Eugen Fahrion GmbH & Co.
Forststrasse 54 | 73667 Kaisersbach | Germany
Phone +49 7184 9282-0
sales@fahrion.de
www.fahrion.de | www.shop.fahrion.de

11/21/F-GHN-EN-BDA